



HI-SKY R/C FLYER

October 2007

Volume 36 Issue 10

President: Bruce Hoover
Vice President: Tommy Thomas
AMA Charter Club #851

Treasurer: Ed Anderson
Secretary: Ralph Gillette
www.hiskyrc.com

Meeting:

The October meeting will be held October 2, 2007 in the First Baptist Church Activity Building at the corner of Garfield and Louisiana streets.. The meeting will start at 7:00 PM.

Hi Sky R/C Club Minutes: September 4, 2007

Meeting was held at the First Baptist Church.

Bruce Hoover brought the meeting to order at 7:10 PM. There were 11 members present.

Minutes: Jim Ruple moved and Ed Anderson seconded that the minutes from the August meeting were approved. Motion passed.

Field Report: Needs more work. Clean up session set for Sunday September 9th at 2:00PM. Needs to be mowed and weeded, both for the Calling all Hogs Fly In and to get rid of the cover for the rattlesnakes. Bruce is working on getting the lock for the shed doors and has found a video camera for security.

Safety Report: A.J. Lee says everything has been safe but wanted to remind everyone that the rattlesnakes are out in force. Good idea not to fly alone, take a buddy.

Activities: Calling of the Hogs is the next event.

continued on page 2

INSIDE THIS ISSUE

- 1 Minutes
- 1 Prop Problems
- 2 Windy Days, Good Rudder Practice Days
- 2 Antennas
- 3 Do You Have an Itch to Scratch?
- 5 For Sale

Propeller Problems

By John Hice
From the Aeroshaft Newsletter, Flint, Michigan

The subject of glow engines backfiring and sending the spinner, propeller, nut, and backplate flying was discussed in "The Engine Shop" article by Joe Wagner (August 2007 issue of Model Aviation). The cause was properly defined as fuel mixture too lean, causing overheating and resultant increased compression and pre-ignition. The correction of course, is a richer fuel mixture. However, there are times when the backfire can occur before you recognize the mixture is too lean, such as the first start after several weeks when atmospheric conditions may require a richer mixture.

There is a simple fix to prevent all that stuff on the end of the crankshaft from spreading over the countryside. Yes, it can happen in the air and your chances of finding any of it are mighty slim. Use a nylon insert nut as a second lock nut, or alone if the shaft is not long enough. Trust me.

More Prop Problems:

We all know that the whirling stick on the pointy end of our airplanes provides the thrust to propel the airplane through the air—thrust being one of the four basic components of flight. (You do remember the other three, don't you?). It also creates four other distinctly different forces that act upon the manner in which the airplane flies. You may or may not be familiar with all of these, which are:

1. Torque
2. Slipstream
3. Asymmetrical Thrust
4. Gyroscopic Precession

Commit these to memory as there will be an exam conducted by nature without prior notification—the way life really is. Torque is most familiar—the equal and opposite reaction to the rotation of the propeller that forces the airplane to rotate (roll) to the left. Because the mass of the airplane is so many times greater than that of the propeller, the roll rate is small but still very noticeable—especially on takeoff when full

continued on page 3

Charge will be \$5.00 for landing, \$5.00 for lunch. The decision was made to get Bratwurst, beans, chips and incidentals. Will get the meat after we find out how many will be there for lunch. Soft drinks from the frig. Bruce will get the Ports-Potties serviced.

Big Spring and Plainview are having electric fly-ins this coming weekend.

Electric Fly – More discussion about going to the Horseshoe next year. Dennis will make contact and see about getting a contract.

Old Business: No old business.
New Business: No new business.

Treasurers Report:

Ed reported that we have money in the savings account and the checking account. Would like to move the savings to a CD to get more interest. AJ Lee moved and Jim Ruple seconded to let Ed make the decision. Approved.

Show and Tell: Rick Strange showed off his new Hog Bipe. Not flown yet, plans first flight tomorrow.

Club Raffle: No raffle

Next meeting: At the First Baptist Activity building, 7:00PM October 2nd.

Meeting adjourned at 8:00 PM.

Windy Days: Good Rudder Practice Days

By Salvatore Piu
From the Ocean County Modelers, Inc., Lakehurst, New Jersey

One of my friends asked me for some flight training, but canceled a few times because of windy conditions. For student pilots—since student pilots usually are flying on a buddy-box system anyway—take advantage of this: get some buddy-box stick time on a windy day.

There are several benefits for students to do this while still using the buddy-box system. First, in order to keep the airplane under desired and controlled conditions, wind generally forces student pilots to be more active to maintain control during the flight, which equates to a faster learning curve.

Second, we always have some amount of wind at the field; therefore pilots should not be afraid of it. Better yet, pilots should learn how to deal with windy

conditions, provided the model is capable of flying in that condition. An electric foamy airplane weighing less than 10 ounces, for instance, should not be flown on windy days, especially by a student pilot or one having recently soloed.

An underpowered or marginally powered model will also be more sensitive to even light wind. The general rule of thumb I use for not flying because it's too windy depends on how hard it is to assemble the model in the wind. If the wind places my model at high risk for damage during assembly, then it's too windy to fly.

I have flown in excessively windy conditions a few times over the years. However, in each case, the flight was no longer enjoyable because I was constantly correcting for wind-related issues, with the landing being the most intensive and nerve-racking part of the flight.

If the wind is a little annoyance during assembly, I will fly knowing the wind will be a little annoyance to contend with in the flight also. I call windy days "good rudder practice days" because rudder typically needs to be used more often on windy flights.

Bottom line: fly a few times in moderate wind conditions while you are a student on a buddy-box system because it will make you a better overall pilot.

Picked up Passing by

This has been a strange month for me. I have been busy and didn't get to fly much. I missed the Callin of the Hogs again because that weekend is my grand-daughter's birthday. I can't miss that. I offered to let Mike Chase take my Astro Hog, but he wouldn't so Chucky had to sit out another event. He didn't get to fly last year either. I am late getting the newsletter out because of other reasons.

I took my Big Stick out to the field one Saturday, but didn't fly because one aileron servo was "sick". It wouldn't move for me at first and later, it would move slowly. I took the plane home and replaced both aileron servos. Could the servo be repaired? Yes, I think so, but it would be cheaper to buy a new servo. This is based upon the service charges posted on the internet. I can't complain because I have had good service from the low end servos.

One of our club members has decided to promote all of the Saturday morning crowd to IMAC flyers. Last year, I couldn't spull I-Mc much less fly with a shark's teeth and bump the hump.

CALENDAR OF EVENTS

We need to discuss plans for events in 2008!

Antennas

From the Aero R/C Club, Lennon, Michigan

With all of the technological advances in transmitters and receivers, we spend more time learning how to use the new features to improve our flying enjoyment. It is easy to forget that these complex signals must be sent from the transmitter to the receiver in the aircraft, and it is the antennas of each that are most important in maintaining a strong signal.

Metal-whip transmitter antennas can take a beating and should be inspected regularly. Inspection before each flying session is not a bad idea. Things have a way of happening during transport to and from the field, and back at the hangar.

Extend the antenna fully and give it a mild shake. Look for slop between the sections as this can cause an intermittent connection. If any section slides back (collapses) without force, replace the antenna. Also check that the antenna is tightly screwed into the base. Sometimes the threaded inserts break loose.

Never use metal gadgets to attach the frequency flag. Clean with tissue and alcohol, and lubricate with WD-40. If a section breaks, it can be soldered together with brass tubing while you wait for a replacement. Receiver antennas must be handled gently. Do not pull on the connection at the receiver body. The antenna should be routed at least 2-inches clear of other electronic parts. When bundling the receiver in foam, be sure the antenna comes out one end and the servo/battery wires out the other. Never attach the receiver antenna with a metal clip. Route it through plastic tubing, or tape it in place. If a portion of antenna breaks off, an extension can be spliced on and covered with shrink tubing. The standard length is 3 meters, but some US makers use 3 feet, and some Park Flyer, single-conversion receivers are less. A few inches in length is not critical.

The new 2.4 GHz radio systems will improve the reliability of antennas because they are only a few inches long, but existing radios have a lot of life in them. In any case, the gold standard for determining a good radio signal is a range check with the engine running. Take the few minutes of time to check your antennas.

Editors note: He states that the "standard length" is "3 meters". This should read 1 meter or 39.37inches. You can make it 39 inches or 39-1/2 inches without a problem.

power is rapidly applied. The airplane wants to turn left.

Slipstream is the movement of air that curls around the airplane as it is blown back by the propeller. In theory, once the airplane reaches speed and achieves equilibrium, there would be no slipstream. This rarely occurs however, and the slipstream can be quite strong as an airplane accelerates from stationary to flight speed during takeoff.

The most noticeable air stream is that coming from the downward turning propeller blade on the right side. This air curls underneath the fuselage, up the left rear side of the airplane, and strikes the rudder on the left side. This will cause the airplane to turn left on takeoff, adding to the effect of torque.

Asymmetrical thrust, also called P-factor, is caused by increasing the angle-of-attack of the airplane. Hold a small airplane straight and level at arms length with the propeller horizontal. Now raise the nose to about a 30° angle up. Look at the propeller from the left side. The pitch (twist) of the blade is nearly vertical. Now look from the right side. The pitch is nearly at a 45° angle. The blade turning down the right side is providing almost all of the thrust! When at slow speed and a steep angle of attack, such as during takeoff, the P-factor is greatest and pulls the nose of the airplane to the left.

Gyroscopic precession is one of those natural forces that were unknown until someone invented a gyroscope and started fooling around with it. It became apparent that when moving a spinning gyro, such as up and down, the gyro tries to move in a 90° direction (sideways). The propeller is a gyroscope, and when tilted up, such as during takeoff, wants to go left. This is the best I can do. If you desire more thorough explanation, many colleges offer physics courses on the Internet.

If you have noticed a theme developing here, give yourself an attaboy! All of these prop-driven forces are trying to roll and turn the airplane to the left, with greatest effect during takeoff. If allowed to continue unchanged, nature will swiftly provide a predictable result. It's like NASCAR—go fast, turn left; but you better have it under control.

We don't stop playing because we grow old; we grow old because we stop playing. George Bernard Shaw

History does not entrust the care of freedom to the weak or timid. General Dwight D. Eisenhower

Do You Have an Itch to Scratch?

By Bill Bowne

The Transmitter, Burlington County NJ

Do you have an itch to scratch? Scratch build, that is. One of the greatest pleasures in modeling is creating your own design—something that no one else at the field has. I've been doing it for more than 20 years, and I still enjoy it.

Let's get one thing straight, before we go any further. When I refer to "scratch build" I mean draw up your own plans and build from them. I don't mean building from someone else's plans, because they've done all the hard thinking for you. Nor do I advocate making scratch builders grow their own balsa trees! I believe that using stock parts and subassemblies from other models in a new model still rates as scratch building, although I can understand how others might differ. The FAA says that if you do 51% of the work in building a full-scale airplane, then it's a home-built airplane. I say it's the same for models.

Okay, how do you get started in scratch building? Actually, you can do it either of two ways. You can plunge right in, or you can work your way in. That's how I started, by working my way in. Kit-bashing, that is, starting with a kit and modifying it until no one could recognize it as a kit. Kit bashing lets you take known good components and combine them with your own ideas. As long as you don't drift too far from the original design (at least, at first), you can't go wrong.

So, let's talk about how to kit bash. The easiest way to start is by changing wing tip and tail shapes. As long as you keep the areas pretty much the same area, all will be well. Don't get paranoid! If the airplane flies well with a 50-square-inch stabilizer, it'll fly just as well with 48- or 52-square-inch one. On the other hand, making a few changes in outlines can make a big difference in the airplane's appearance.

Going further, you can make a high-winged airplane into a shoulder or low-winged one. You'll lose some stability as you go, so either increase the dihedral or add ailerons! When I converted a Little Stik into a low winger, for example, I traced the side view of the fuselage and wing, and then moved the wing profile straight down to the bottom of the fuselage. This is where the plans come in handy; just flip them over and trace through them. If you can't quite see through, apply a little oil and the plans will turn transparent—that's cooking oil or clean machine oil. Don't use your old, filthy lawnmower oil and complain about it being opaque! [Technical Editor's note: this is very messy and you must cover the oiled plan to keep it from getting oil on the balsa or anything else.] Keep the stabilizer the same distance back from the wing and keep the same center of gravity.

A Xerox makes replicating the wing side view much easier, provided the Xerox makes true copies. I've run into several that didn't. To check, compare the copy with the original. Or Xerox a ruler and compare that to the original. (As a side note, it's always a good idea to trace or Xerox the ribs and bulkheads when you build a kit, so you have templates for repairs. If you Xerox them, of course, make sure they match the originals!)

When you change the wing's position, you'll have to redo the fuselage side. One solution, popular with fully-symmetrical wings, is to just flip the fuselage over. Since the top and bottom of the wing are the same, the wing saddle matches both ways. If you can't do that, then copy as much as you can. Use the same structural methods the original designer did; just change the shapes of the parts.

The hardest part of making a model into a low-winger is usually the landing gear. If you're using foam wings, this is easy; you can even buy preshaped landing gear blocks. One of the reasons I like taildraggers is how easy it is to set them up. For a taildragger, if you don't want to diddle with plywood ribs and the complexities of mounting the landing gear in the wing, just mount it at the wing leading edge. As long as you make sure the gear sweeps back enough so that the axle is under the leading edge of the wing, you should be okay.

Part of the fun of kit bashing is that you can improve an airplane's performance as you go, for example, adding bottom rudder. When the rudder is deflected, it exerts a sideways push on the tail of the airplane. If most of the rudder is above the airplane's center of gravity (as seen from the rear), the push will add roll to the airplane's yawing motion. Please, don't confuse this with adverse yaw! One way to cure it is by mixing in aileron compensation via a computerized transmitter but if you can design it out, you don't need the fancy transmitter!

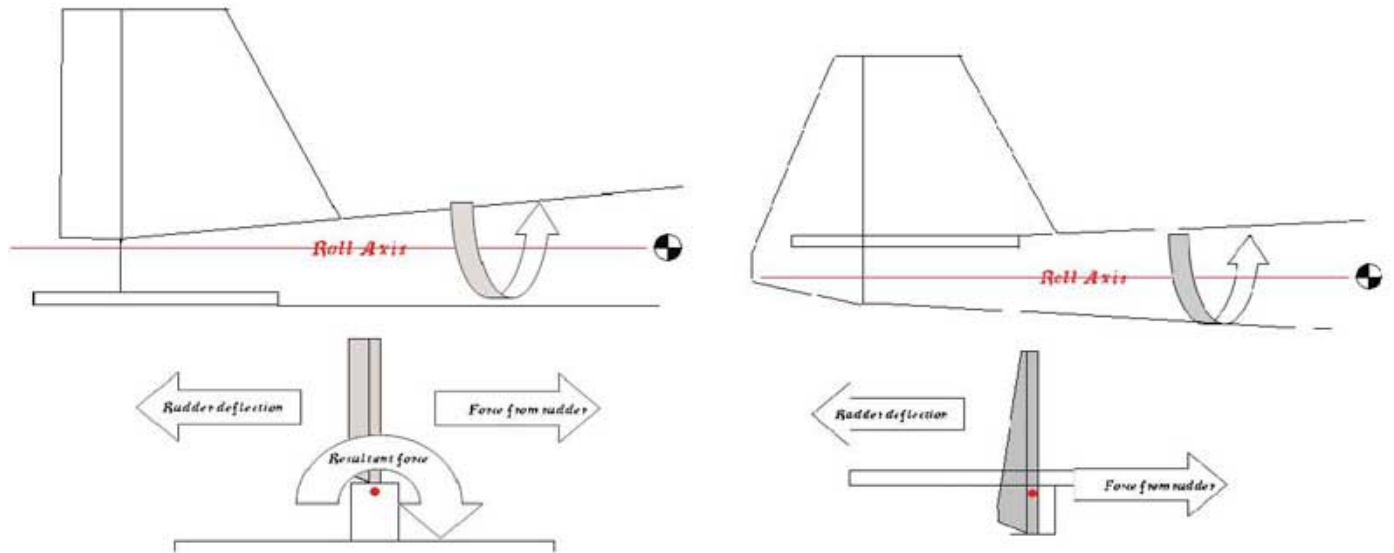

Here's a typical top rudder (as in an Ugly Stik). Notice that when the rudder is deflected to the left, the airplane rolls to the right (The red dot in the rear view is the roll axis as seen from behind). My Sylph has this pretty badly—I can turn the model on rudder and elevator alone, without any need for aileron. But, if you move a large portion of the rudder down below the roll axis, you reduce the effect of the rudder on rolling. This is great, if you plan to do stall turns, slips, crabbing, or other maneuvers that entail rudder. Ever notice how all those Extras, CAPS, and other aerobatic full-scale models have their rudders shaped?

But kit bashing can go further than moving the wing up or down or changing the tail shapes. You could start with a common low-wing sport kit such as the 4-Star series, then add a turtle-deck and chin scoop. Throw in some block for a streamlined spinner, curved tail surfaces, and dummy landing gear housings, and you have a "Sorta P-40."

Remember, most of an airplane's personality is in the fuselage, so even if you use a Hershey bar wing on an Me-109, most of the personality will be there. Heck, it'll be a lot easier to fly, too! Unless you plan to compete in a Scale event, what does it matter? I'd rather have a good-looking airplane that looks well, than a great-looking one I'm too scared to fly!

Or, take two Stiks and make a "Zwilling" (twin fuselage). If you use a constant-chord wing, all you need to do is cut out more ribs. If you do a twin of something like a Kougaur, use the root chord for a constant chord center section.

Start simple, then work your way up. At first, you'll see people staring at your model, trying to figure out what's different about it. Finally, they'll get it. As you get more into kit bashing, you'll see them take longer and longer to figure it out. Finally, they'll have to ask you those sweet words: "Okay, I give up. What is it?"

For Sale:

- Top Flite Spitfire kit... 0.60 size... Complete NIB \$75.00
- Top Flite Airacorba kit 0.60 size with cockpit kit. \$75.00
- World Models Clipped wing Cub (electric power) ARF new in the box. \$60.00
- Horizon Hobbies PT-19 (electric power) ARF new in the Box. Almost ready to go. \$60.00
- Contact Bill Coombes at 689-8359 or email at: Snj24@earthlink.net

- 1 - Futaba T6EXA transmitter w/charger-channel 31.
- 1 - Great Planes ElectriFly ACPark Flyer Peak Charger.
- 1 - Hitec Electron 5 Micro-receiver.
- 1 - Great Planes ElectrFly C-10 Micro ESC.
- 4 - micro servos
- 1 - GWS EM 350 motor with prop.

MAKE OFFER

Contact Jon Wheeler via e-mail @ jwheeler@keyenergy.com

FOR SALE

- Futaba Buddy Box and training cord \$20**
- Airtronics Buddy Box and training cord
And carrying case \$25**
- Dave Brown Six Shooter Fuel pump \$5**
- Futaba 6EXA programmable computer radio, \$95
Extra battery, wall charger and manual
And Berg 4L micro receiver with matching crystal**
- Berg 4L receiver crystals for channel 33 or 39 \$5 each**
- Complete high wing (rudder, elev.) \$45
slow fly plane, Includes:
Brushless outrunner motor
Brushless 12A speed control
2-GWS servos
(W/Berg 4L receiver \$65)**



Almost New SPARK shock/3D flyer \$80

Includes:

Brushless motor

12A brushless speed control

3-servos

(W/Berg 4L receiver

\$100)



Huge assortment of balsa, including sheets, sticks, and plywood. All for \$75 You need to see this to appreciate the price!

Call Dennis Robbins at 699-2465 to see, or I can bring to the meeting in October. Let me know in advance, and I can demo fly the planes at the meeting